



# JX1

## Medium Level Order Picker 0.5t

High volume order picking in a warehouse environment;  
Max Platform height: 4.80m – Picking height 6.3m;  
Truck Size 1590x1500x800, turning radius (1385),  
suitable for narrow aisles in the warehouse;  
Strong and steady;  
AGM Battery (maintenance free), Large Lead–Acid battery  
as option. Simple Battery exchange.

**EP EQUIPMENT CO.,LTD**  
[www.ep-ep.com](http://www.ep-ep.com)



# Medium Level Order Picker 0.5t

## JX1

Distinguishing mark	1.1	Manufacturer			EP	EP	EP
	1.2	Model designation			JX1(3200)	JX1(4100)	JX1(4880)
	1.3	Drive			Electric	Electric	Electric
	1.4	Operator type			Order-picker	Order-picker	Order-picker
	1.5	Load capacity	Q	kg	227/137/136	227/137/136	227/137/136
	1.6	Load center distance	c	mm	—	—	—
	1.8	Load distance, centre of drive axle to fork	x	mm	—	—	—
	1.9	Wheelbase	y	mm	1150	1150	1256
	Service weight	2.1	Service weight			1160	1340
2.2		Axle loading, laden front/rear			680/980	740/1100	780/1220
2.3		Axle loading, unladen front/rear			490/670	520/820	540/990
Tyres/chassis	3.1	Tyre type			Polyurethane/Solid rubber	Polyurethane/Solid rubber	Polyurethane/Solid rubber
	3.2	Tyre size, front		mm	Φ230×75	Φ230×75	Φ230×75
	3.3	Tyre size, rear		mm	Φ204×76	Φ204×76	Φ204×76
	3.4	Additional wheels (castor wheels)		mm	Φ74×48	Φ74×48	Φ74×48
	3.5	Wheels, number front/rear (x=drive wheels)		mm	1x,2/2	1x,2/2	1x,2/2
	3.6	Tread width, front	b10	mm	555	555	615
	3.7	Tread width, rear	b11	mm	740	740	784
Dimensions	4.2	Retracted mast height	h1	mm	1510	2080	2090
	4.3	Free lift	h2	mm	—	—	—
	4.4	Lift height	h3	mm	4030	4930	5710
	4.5	Height, mast extended	h4	mm	4540	5970	6750
	4.7	Height of overhead guard (cabin)	h6	mm	1590	2120	2120
	4.8	Seat height/standing height	h7	mm	250	250	250
	4.14	Stand height, elevated	h12	mm	3200	4100	4880
	4.15	Lowered height	h13	mm	—	—	—
	4.19	Overall length	l1	mm	1500	1500	1610
	4.20	Length to face of forks	l2	mm	—	—	—
	4.21	Overall width	b1/b2	mm	800	800	860
	4.22	Fork dimensions	s/e/l	mm	—	—	—
	4.25	Distance between fork-arms	b5	mm	—	—	—
	4.32	Ground clearance, center of wheelbase	m2	mm	50	50	50
	4.34.1	Aisle width for pallets 1000×1200 crossways	Ast	mm	—	—	—
4.34.2	Aisle width for pallets 800×1200 crossways	Ast	mm	—	—	—	
4.35	Turning radius	Wa	mm	1385	1385	1450	
Performance data	5.1	Travel speed, laden/unladen		km/h	5.5/5.5	5.5/5.5	5.5/5.5
	5.2	Lifting speed, laden/unladen		m/s	0.17/0.21	0.17/0.21	0.17/0.21
	5.3	Lowering speed, laden/unladen		m/s	0.35/0.26	0.35/0.26	0.35/0.26
	5.8	Max. gradeability, laden/unladen		%	0	0	0
	5.10	Service brake			Electromagnetic	Electromagnetic	Electromagnetic
Electric-engine	6.1	Drive motor rating S2 60 min		kW	1.7	1.7	1.7
	6.2	Lift motor rating at S3 15%		kW	2.2	2.2	2.2
	6.4	Battery voltage/nominal capacity		V/Ah	24/224	24/224	24/280
	6.5	Battery weight		kg	163	163	250
	Addition data	8.1	Type of drive control			AC	AC
10.5		Steering design			Electronic	Electronic	Electronic
10.7		Sound pressure level at the driver's ear		dB(A)	74	74	74

If there are improvements of technical parameters or configurations, no further notice will be given.  
The diagram shown may contain non-standard configurations.

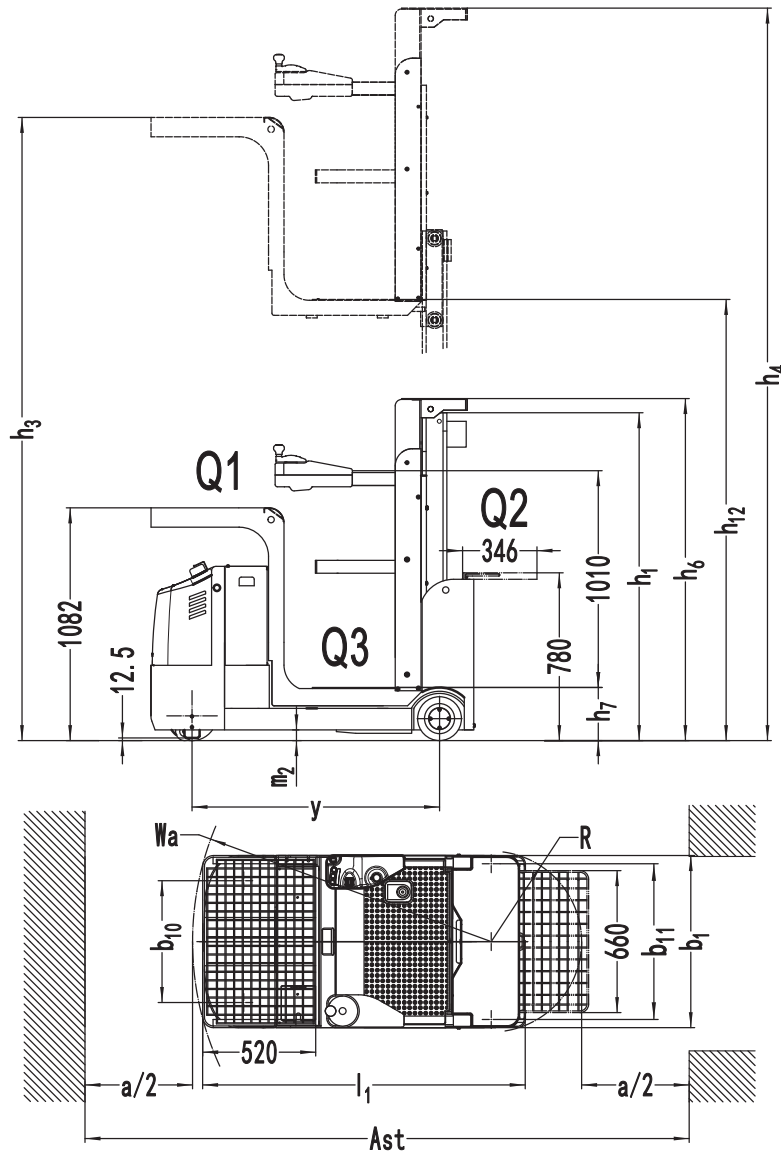

## Option

No.	Optional items	JX1(3200, 4100)	JX1(4800)
2.1	Load wheel type		●Single
2.2	Load wheel material		●Rubber
2.3	Drive wheel material		●PU
2.7	Battery capacity	○224AH AGM○210AH Lead-acid ○270AH Lead-acid○205AH Li-ion	○224AH AGM○280AH Lead-acid ○360AH Lead-acid○205AH Li-ion
2.8	Charger	○24V-25A Internal (Only for 224AH AGM battery) ○24V-40A External (Only for Lead-acid battery) ○24V-27.1A Internal (Only for 205AH Li-ion battery)	○24V-25A Internal (Only for 224AH AGM battery) ○24V-50A External (Only for Lead-acid battery) ○24V-27.1A Internal (Only for 205AH Li-ion battery)
2.9	Battery indicator		●With time
2.12	Safe hook		●No○Yes and not customized
2.13	Traction pin		●No○Yes and not customized
2.14	Electrostatic chain		●No
3.3	Castor wheels		●Yes and not customized
3.4	Water auto-filling system		●No
3.7	Warning lamp	●Front and rear warning light○Front blue light + rear warning light○Front blue light + front warning light	
3.12	Hummer		●Drop buzzer, door alarm buzzer, dip buzzer○Running buzzer○Reversing buzzer
3.18	Guide wheel		●No○Yes and not customized
3.19	USB interface		●No○Yes and not customized
4.1	Battery side pull function		●Yes and not customized
4.7	Overhead guard		●No
5.1	Battery side pull attachment		●No○Yes and not customized

Note: ●Standard ○ Optional - Inconformity