

GP 151

1500kg 3-Wheel Electric Counterbalance Forklift



- Super-Compact 3 wheel truck designed around AGM maintenance free battery.
- Perfect machine for light to medium applications in confined spaces.
- Reduced overhead guard height (2000mm) to work under low floors and pass through doors.
- Great ergonomic design with adjustable steering wheel and comfortable bucket seat.
- Powerful AC traction motor.
- AGM maintenance free battery for improved efficiency, good autonomy and occasional charging.
- Single phase integrated charger with 16A plug.



Manufacturer			EP
Model designation			EFS151
Drive			Electric
Load capacity	Q	kg	1500
Load center distance	c	mm	500
Service weight		kg	2200
Retracted mast height	h1	mm	1980
Lift height	h3	mm	3000
Height, mast extended	h4	mm	4054
Length to face of forks	l2	mm	1797
Overall width	b1/b2	mm	1060
Fork dimensions	s/e/l	mm	40x100x920
Turning radius	Wa	mm	1535
Travel speed, laden/unladen		km/h	8/9
Lifting speed, laden/unladen		m/s	0.25/0.3
Lowering speed, laden/unladen		m/s	0.44/0.425
Max. gradeability, laden/unladen		%	10/12
Drive motor rating S2 60 min		kW	6
Battery voltage/nominal capacity		V/Ah	48/150

FEATURES

Ideal for space with low-ceilings

EFS151 demonstrates a compact design especially at the height <2.0m which makes it an ideal vehicle to perform the tasks in spaces with low ceilings such as malls, older factories, underground parking, garages, cargo lifts and older warehouses even with a 3 stage 4350mm lift mast. This 3-wheel truck also features a small turning radius 1535mm and light weight 2200kg, offering great maneuverability in narrow aisles and under mezzanines.

Lithium technology with integrated charger

EFS151 adopts a maintenance-free 48V/180Ah AGM Battery and a 48V/30A internal charger, which delivers more charging convenience and increased uptime due to opportunity charging, better fitting in 24/7 operations.

Bluetooth preventive service app for maintenance efficiency

GP 151 guarantees a high level of maintenance efficiency with EP preventive service app that enables operators to connect the truck via bluetooth for parameter changes and monitoring as well as diagnostics trouble code reading without a handheld unit.

Market-proven components

GP 151 adopts market-proven reliable components that encourage its long service life.



GP 151 - Electric Counterbalance Forklift 1.5T

Distinguishing mark	1.1	Manufacturer			EP	EP
	1.2	Model designation			EFS151 (Li-ion)	EFS151 (Lead acid)
	1.3	Drive			Electric	Electric
	1.4	Operator type			Seated	Seated
	1.5	Load capacity	Q	kg	1500	1500
	1.6	Load center distance	c	mm	500	500
	1.8	Load distance, centre of drive axle to fork	x	mm	265	265
	1.9	Wheelbase	y	mm	1275	1275
	Service weight	2.1	Service weight		kg	2200
2.2		Axle loading, laden front/rear		kg	3290/410	3290/410
2.3		Axle loading, unladen front/rear		kg	890/1310	890/1310
Tyres/chassis	3.1	Tyre type			Solidrubber	Solidrubber
	3.2	Tyre size, front			330×145	330×145
	3.3	Tyre size, rear			16×6-8	16×6-8
	3.5	Wheels, number front/rear (x=drive wheels)		mm	2/1x	2/1x
	3.6	Tread width, front	b ₁₀	mm	905	905
	3.7	Tread width, rear	b ₁₁	mm	—	—
	Dimensions	4.1	Tilt of mast/fork carriage forward/backward	α/β	°	3/5
4.2		Retracted mast height	h ₁	mm	1980	1980
4.3		Free lift	h ₂	mm	100	100
4.4		Lift height	h ₃	mm	3000	3000
4.5		Height, mast extended	h ₄	mm	4054	4054
4.7		Height of overhead guard (cabin)	h ₅	mm	1995	1995
4.8		Seat height/standing height	h ₇	mm	985	985
4.12		Tow coupling height	h ₁₀	mm	660	660
4.19		Overall length	l ₁	mm	2717	2717
4.20		Length to face of forks	l ₂	mm	1797	1797
4.21		Overall width	b ₁ /b ₂	mm	1060	1060
4.22		Fork dimensions	s×e×l	mm	40×100×920	40×100×920
4.23		A,B Fork carriage class/type A, B			2A	2A
4.24		Fork carriage width	b ₃	mm	1040	1040
4.31		Ground clearance, laden, below mast	m ₁	mm	90	90
4.32		Ground clearance, center of wheelbase	m ₂	mm	78	78
4.34.1		Aisle width for pallets 1000×1200 crossways	Ast	mm	3000	3000
4.34.2		Aisle width for pallets 800×1200 lengthways	Ast	mm	3200	3200
4.35		Turning radius	Wa	mm	1535	1535
Performance data	5.1	Travel speed, laden/unladen		km/h	8/9	8/9
	5.2	Lifting speed, laden/unladen		m/s	0.25/0.3	0.25/0.3
	5.3	Lowering speed, laden/unladen		m/s	0.44/0.425	0.44/0.425
	5.5	Drawbar pull, laden/unladen		N	—	—
	5.6	Max. drawbar pull, laden/unladen		N	—	—
	5.8	Max. gradeability, laden/unladen		%	10/12	10/12
	5.10	Service brake			Hydraulic	Hydraulic
5.11	Parking brake			Mechanical	Mechanical	
Electric-engine	6.1	Drive motor rating S2 60 min		kW	6	6
	6.2	Lift motor rating at S3 15%		kW	5.5	5.5
	6.4	Battery voltage/nominal capacity		V/Ah	48V/150Ah	48V/180Ah
Addition data	8.1	Type of drive control			AC	AC
	10.5	Steering design			Hydraulic	Hydraulic
	10.7	Sound pressure level at the driver's ear		dB(A)	70	70

If there are improvements of technical parameters or configurations, no further notice will be given.
The diagram shown may contain non-standard configurations.

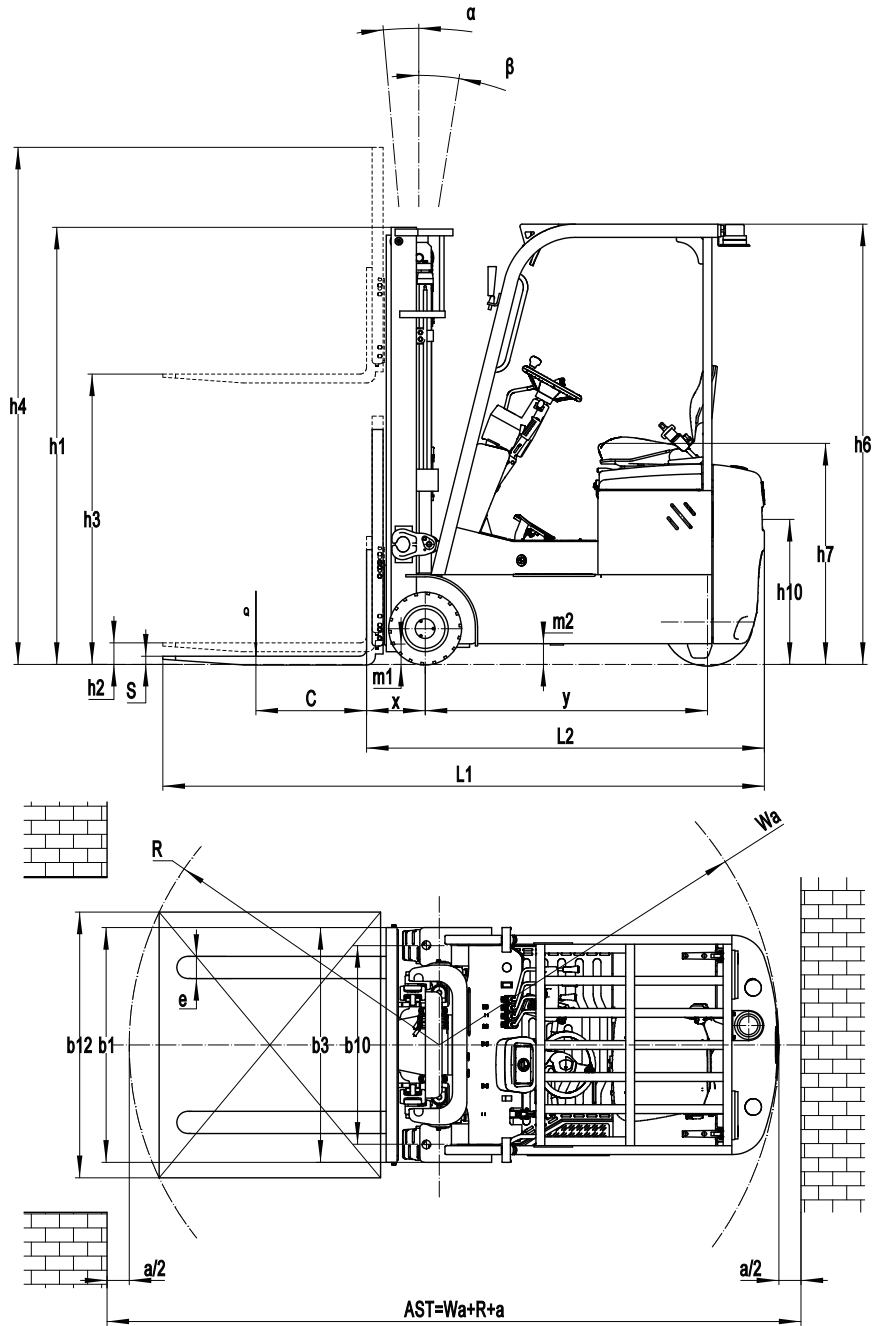

RATED CAPACITIES AND LOAD CENTERES GRAPH

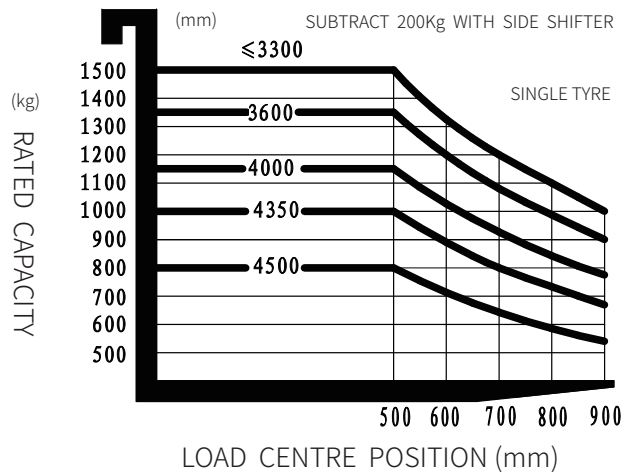

Mast Option

Mast types	Lift height (h3)	Height, Mast			Height, Free lift(h2)	
		Height, mast lowered(h1)	Height, mast extended(h4)		No backrest	With backrest
	No backrest		With backrest	mm		
2-Standard Mast	2500	1730	3046	3554	100	100
	2700	1830	3246	3754	100	100
	3000	1980	3546	4054	100	100
	3300	2130	3846	4354	100	100
	3600	2280	4146	4654	100	100
2-Free Mast	3000	2010	3546	4054	1494	986
	3300	2160	3846	4354	1644	1136
	3600	2310	4146	4654	1794	1286
3-Free Mast	4000	1830	4546	5054	1314	806
	4350	1980	4896	5404	1464	956
	4500	2030	5046	5554	1514	1006

Option

No.	Optional items	EFS151
1.1	Fork dimension	●100*40*920○100*40*1070○100*40*1100○100*40*1150 ○100*40*1220○100*40*1370○100*40*1520
1.4	Fork carriage width	●1040mm○Yes and can be customized
1.5	Fork carriage height	●1025mm○Yes and can be customized
2.5	Front wheel material	●solid○Non-marking
2.6	Rear wheel material	●solid○Non-marking
2.7	Battery capacity	○48V180AH (AGM) ○48V150AH (LI-ION)
2.8	Charger	○48V30A external charger for AGM battery ○48V30A internal charger for Li-ion battery ○48V50A internal charger for Li-ion battery
2.9	Battery indicator	●With time
2.10	Seat type	●Regular○Premium
2.11	Attachments	●No○Built-in sideshifter○External shifter○Fork positioner
2.13	Traction pin	●Yes
3.5	Front lamp	●LED
3.6	Rear lamp	●NO○LED
3.7	Warning lamp	●Yes
3.8	Steering lamp	●Yes
3.9	Blue lamp	●NO○2 front○1 rear○2 front + 1 rear
3.10	Area warning lamp	●NO ○Red, 1 left + 1 right
3.11	Rearview mirror	●One in the middle○Two on both sides
3.12	Buzzer	●Yes
3.17	OPS system	●NO○Yes and not customized
3.23	Telematics	●NO○Yes and not customized

Note: ●Standard ○ Optional - Inconformity