



## EPT20-20 WA

### 2000kg Heavy-duty Pallet Truck

- > Heavy duty truck for short distance intense applications
- > Powerful vertical AC traction motor with gearbox
- > Long tiller for excellent manovrability
- > Automatic speed reduction based on tiller position
- > Small turning radius and over 180` tiller rotation range

Manufacturer			EP	EP
Model designation			EPT20-20WA	EPT25-WA
Drive			Electric	Electric
Load capacity	Q	kg	2000	2500
Load center distance	c	mm	600	600
Service weight			400	400
Length to face of forks	l2	mm	621	621
Overall width			710	710
Fork dimensions			55/170/1150	55/170/1150
Turning radius			1600	1600
Max. gradeability, laden/unladen			8/16	8/16
Battery voltage/nominal capacity			V/Ah	24/205

# FEATURES



## Performance

- The innovative AC system offers strong power, accurate control and excellent performance.
- High strength vertical gearbox provides reliable uptime.
- Low-noise and durable hydraulic unit, high quality cylinder as well as hose ensure the high reliability of hydraulic system.
- AMP connector and durable electric wires greatly reduce malfunctions of components.
- One-time formed fork, box type frame and adjustable linkage extends the life of undercarriage.



## Safety

Curved design of front chassis avoids pinching point when lifting.  
Curved design of bottom frame ensures proper ground clearance and avoids hurting operator's feet.  
Emergency reverse belly button protects the operator from getting hurt.  
Emergency disconnecter will cut off power source to avoid accident when the truck goes out of control.  
Anti-rolling back brake keeps the truck from skidding down when truck is out of control or travelling on ramp.  
LBR option avoids cargo from falling down.  
Long operation tiller withstands most impacts from crashes.

## Operation

With the new design of ergonomical tiller head, all buttons can be reached conveniently & comfortably.  
Thanks to the long tiller design, it decreases the steering force greatly which leads to easy operations.  
With its special fork design, it is suitable for all popular pallets.  
Over 180° handle rotation range tiller & compact size ensure small turning radius & excellent maneuverability.  
Creep speed function: when tiller is in near vertical position, the driving speed will decrease automatically, allowing delicate operation in confined space.  
Creep Switch for vertical handle (optional).

## Maintenance

AC traction motor, maintenance free.  
Hour meter and battery indicator remind the operator of battery charging.  
Easily remove the back cover by only loosening two bolts; Access to all key components for inspection, maintenance and replacement.  
Easy access for battery maintenance.  
Vertical motor makes the inspection & service much more convenient.  
Control system allows easy trouble-shooting.  
Low voltage lift cut off design protects batteries.

# Electric Pallet Truck 2.0t

## EPT 20 - 20 WA

Distinguishing mark	1.1	Manufacturer			EP	EP
	1.2	Model designation			EPT20-20WA (Lead-acid)	EPT20-20WA (Li-ion)
	1.3	Drive			Electric	Electric
	1.4	Operator type			Pedestrian	Pedestrian
	1.5	Load capacity	Q	kg	2000	2000
	1.6	Load center distance	c	mm	600	600
	1.8	Load distance, centre of drive axle to fork	x	mm	916 / 982	916 / 982
	1.9	Wheelbase	y	mm	1418	1418
	Service weight	2.1	Service weight		kg	530
2.2		Axle loading, laden front/rear		kg	950 / 1580	820 / 1580
2.3		Axle loading, unladen front/rear		kg	425 / 105	295 / 105
Tyres/chassis	3.1	Tyre type			Polyurethane	Polyurethane
	3.2.1	Tyre size, front		mm	Φ85x70	Φ85x70
	3.3.1	Tyre size, rear		mm	Φ230x75	Φ230x75
	3.4	Additional wheels (castor wheels)		mm	Φ85x48	Φ85x48
	3.5	Wheels, number front/rear (x=drive wheels)		mm	1 x +2 / 4	1 x +2 / 4
	3.6.1	Tread width, front	b10	mm	498	498
	3.7.1	Tread width, rear	b11	mm	515	515
Dimensions	4.4	Lift height	h3	mm	120	120
	4.9	Height of tiller handle in drive position min./max.	h14	mm	715 / 1200	715 / 1200
	4.15	Lowered height	h13	mm	85	85
	4.19	Overall length	l1	mm	1748	1748
	4.20	Length to face of forks	l2	mm	621	621
	4.21	Overall width	b1/b2	mm	710	710
	4.22	Fork dimensions	s/e/l	mm	55 x 170 x 1150	55 x 170 x 1150
	4.25	Distance between fork-arms	b5	mm	685	685
	4.32	Ground clearance, center of wheelbase	m2	mm	30	30
	4.34.1	Aisle width for pallets 1000×1200 crossways	Ast	mm	2400	2400
	4.34.2	Aisle width for pallets 800×1200 crossways	Ast	mm	2255	2255
4.35	Turning radius	Wa	mm	1600	1600	
Performance data	5.1	Travel speed, laden/unladen		km/ h	5 / 5.5	5 / 5.5
	5.2	Lifting speed, laden/unladen		m/s	0.051 / 0.060	0.051 / 0.060
	5.3	Lowering speed, laden/unladen		m/s	0.032 / 0.039	0.032 / 0.039
	5.8	Max. gradeability, laden/unladen		%	8 / 16	8 / 16
	5.10	Service brake			Electromagnetic	Electromagnetic
Electric-engine	6.1	Drive motor rating S2 60 min		kW	1.1	1.1
	6.2	Lift motor rating at S3 15%		kW	0.84	0.84
	6.4	Battery voltage/nominal capacity		V/Ah	24 / 210	24 / 205
	6.5	Battery weight		kg	190	62
Addition data	8.1	Type of drive control			AC	AC
	10.5	Steering design			Mechanical	Mechanical
	10.7	Sound pressure level at the driver's ear		dB(A)	74	74

If there are improvements of technical parameters or configurations, no further notice will be given.  
The diagram shown may contain non-standard configurations.

# Electric Pallet Truck 2.5t

## EPT25-WA

			EP	EP		
			EPT25-WA(Lead-acid)	EPT25-WA(Li-ion)		
Distinguishing mark	1.1	Manufacturer				
	1.2	Model designation				
	1.3	Drive	Electric	Electric		
	1.4	Operator type	Pedestrian	Pedestrian		
	1.5	Load capacity	Q	kg	2500	2500
	1.6	Load center distance	c	mm	600	600
	1.8	Load distance, centre of drive axle to fork	x	mm	916 / 982	916 / 982
	1.9	Wheelbase	y	mm	1418	1418
	Service weight	2.1	Service weight		kg	565
2.2		Axle loading, laden front/rear		kg	985 / 1580	820 / 1580
2.3		Axle loading, unladen front/rear		kg	460 / 105	295 / 105
Tyres/chassis	3.1	Tyre type			Polyurethane	Polyurethane
	3.2.1	Tyre size, front		mm	Φ85x70	Φ85x70
	3.3.1	Tyre size, rear		mm	Φ230x75	Φ230x75
	3.4	Additional wheels (castor wheels)		mm	Φ85x48	Φ85x48
	3.5	Wheels, number front/rear (x=drive wheels)		mm	1 x +2 / 4	1 x +2 / 4
	3.6.1	Tread width, front	b10	mm	498	498
	3.7.1	Tread width, rear	b11	mm	515	515
Dimensions	4.4	Lift height	h3	mm	120	120
	4.9	Height of tiller handle in drive position min./max.	h14	mm	715 / 1200	715 / 1200
	4.15	Lowered height	h13	mm	85	85
	4.19	Overall length	l1	mm	1748	1748
	4.20	Length to face of forks	l2	mm	621	621
	4.21	Overall width	b1/b2	mm	710	710
	4.22	Fork dimensions	s/e/l	mm	55 x 170 x 1150	55 x 170 x 1150
	4.25	Distance between fork-arms	b5	mm	685	685
	4.32	Ground clearance, center of wheelbase	m2	mm	30	30
	4.34.1	Aisle width for pallets 1000×1200 crossways	Ast	mm	2400	2400
	4.34.2	Aisle width for pallets 800×1200 crossways	Ast	mm	2255	2255
4.35	Turning radius	Wa	mm	1600	1600	
Performance data	5.1	Travel speed, laden/unladen		km/ h	5 / 5.5	5 / 5.5
	5.2	Lifting speed, laden/unladen		m/s	0.051 / 0.060	0.051 / 0.060
	5.3	Lowering speed, laden/unladen		m/s	0.032 / 0.039	0.032 / 0.039
	5.8	Max. gradeability, laden/unladen		%	8 / 16	8 / 16
	5.10	Service brake			Electromagnetic	Electromagnetic
Electric-engine	6.1	Drive motor rating S2 60 min		kW	1.1	1.1
	6.2	Lift motor rating at S3 15%		kW	0.84	0.84
	6.4	Battery voltage/nominal capacity		V/Ah	24 / 240	24 / 205
	6.5	Battery weight		kg	220	62
Addition data	8.1	Type of drive control			AC	AC
	10.5	Steering design			Mechanical	Mechanical
	10.7	Sound pressure level at the driver's ear		dB(A)	74	74

If there are improvements of technical parameters or configurations, no further notice will be given.  
The diagram shown may contain non-standard configurations.

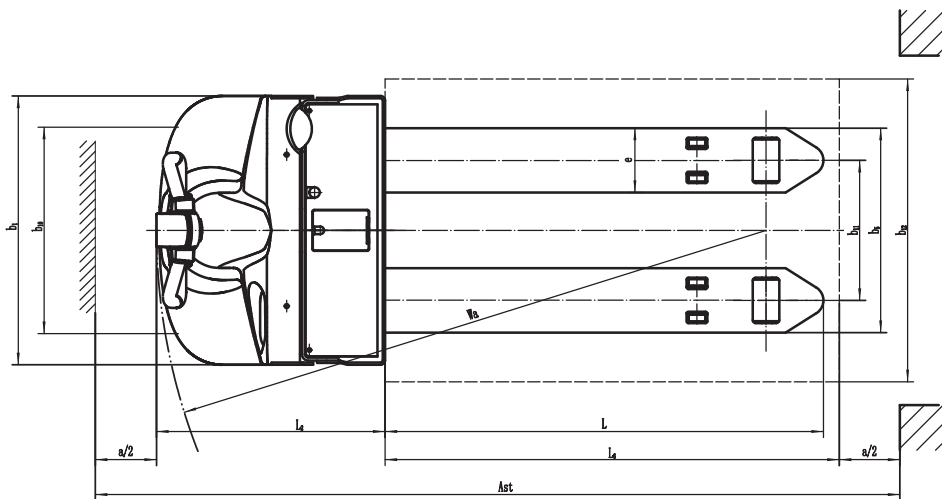
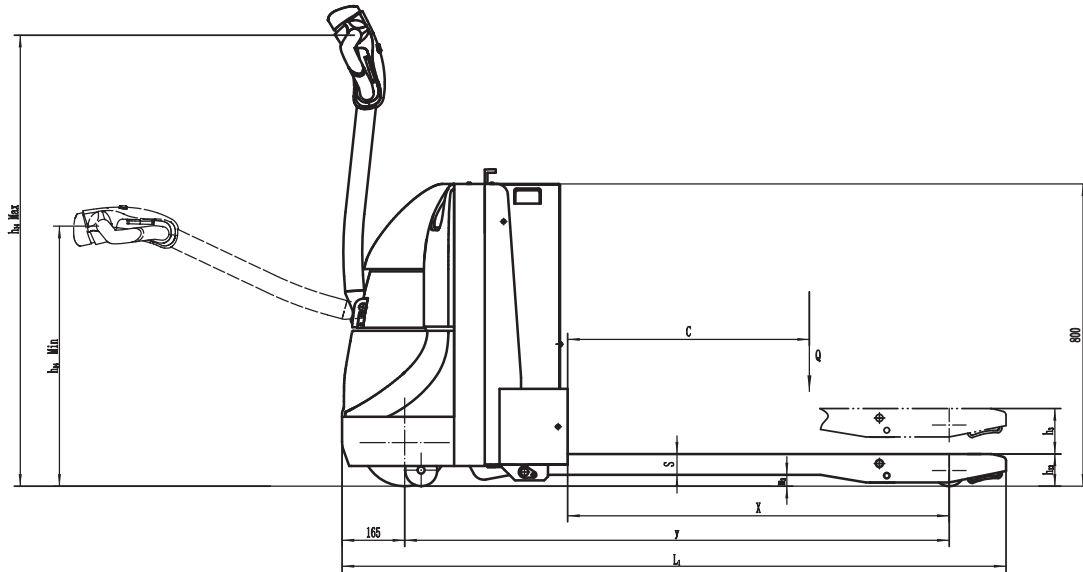

## Load Capacity Chart

Fork length (mm)	Load capacity (kg)
	EPT20-20WA
850	2000KG
1000	
1150	
1220	
1300	
1450	1800KG
1600	
1800	
2000	1600KG
2200	
2400	

## Option

No.	Optional items	EPT20-20WA/EPT25-WA
1.1	Fork length	●1150/1220○850/1000/1300/1450/1600/1800/2000 /2200/2400
1.2	Fork width	●540/685○600/725/790/840/940/1000/1050 /1100/1200
1.3	Fork lowered height	●85
1.4	Fork carriage width	726
1.5	Fork carriage height	○1220mm (48in) ○1520mm (60in)
2.1	Load wheel type	●Double○Single
2.2	Load wheel material	●PU
2.3	Drive wheel material	●PU○Trace PU○Rubber
2.7	Battery capacity	●205Ah●210Ah (Lead Acid battery) ○240Ah (Lead Acid battery)
2.8	Charger	●24V-100AExternal○24V-50AExternal ●24V-30AExternal (Lead Acid battery) ○24V-50AExternal (Lead Acid battery)
2.9	Battery indicator	●Yueli Hourmeter (With time)
3.3	Castor wheels	●Yes and not customized
3.4	Water auto-filling system	○Yes and not customized
3.16	Vertical handler working	●Vertical handler working
4.1	Battery side pull function	○Battery side pull function
4.2	Cold storage	○Cold storage
4.4	Weighting system with fork	○Weighting system with fork
Note: ●Standard ○ Optional - Inconformity		