

B313 FWD

Bendi

Battery Electric Multi-Purpose Articulated Forklift Truck

Designed to give optimal aisle performance whilst retaining many of the features which have made the award winning Bendi the first choice in articulated forklift trucks, the B313 is capable of storing pallets in 1.6m aisles offering great space savings over counterbalance and reach trucks. Bendi can achieve a storage density that exceeds that of a very narrow aisle (VNA) installation.



Features

- Battery electric
- 1350kg capacity
- 7.15m lift
- 1.6m aisle
- Dual inside / outside capability

Ergonomics & Safety

- Comfortable seating position with all truck functions to hand
- No 'deadman switch' required as rotation fully visible from drivers cab
- Four post overhead guard
- Full hydraulic power steering

Drivetrain

- Large soft tyres
- Regenerative braking
- Powerful 8kW AC drive motor
- 220° over rotating steering

Electrical System

- 48 volt high capacity battery
- Maintenance free AC control
- Battery and status monitoring display
- Provision for radio data terminals / RFID reader

Engineering

- Full backwards and forwards tilting mast
- Accepts all standard attachments
- Lifetime warranty on articulation unit
- Award winning chassis design
- Patented front wheel drive



B313 FWD

Battery Electric Multi-Purpose Articulated Forklift



Model				B313
Capacity			kg	1350
Load centre			mm	500
Power source				Traction Battery
Unladen weight including battery			kg	6000
Sideshift				Integral
Travel speed (Adjustable)		Laden / Unladen	kph	11/12
Lift Speed		Laden / Unladen	m/s	0.4/0.5
Lower speed		Laden / Unladen	m/s	0.5/0.3
Tilt range		Fore/Rear	°	1/3
Overhead guard height	g		mm	2250
Seat height	f		mm	1220
Cab floor height	e		mm	700
Minimum ground clearance	d		mm	60
Lost load centre	a		mm	270
Overall length to face of forks	c		mm	2600
Wheelbase	b		mm	1800
Chassis width	h		mm	1150
Maximum gradient			%	15
Rotation angle			°	220
Combined Lift and power steer motor rating			kW	8
Drive motor rating - AC			kW	8
Wheel size		Front / Rear	mm	406 x 200 / 460 x 180
Battery type, standard		630	Ah	7PZSH630
Minimum battery weight			kg	970
Control type				AC

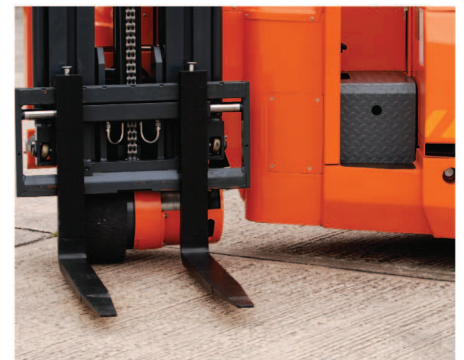

Mast Dimensions

Standard triple full free lift mast

Lift Height	Free Lift	Closed Height	Extended Height	Lift Height
5000 mm	1750 mm	2599 mm	5849 mm	5000 mm
6000 mm	2117 mm	2966 mm	6849 mm	6000 mm
7150 mm	2500 mm	3349 mm	7999 mm	7150 mm

All heights are stated without load backrest, if fitted.

Aisle Dimensions

Load Depth x Width (j x i)	Minimum Clear Aisle
1000mm D x 1200mm W	1600 mm
1200mm D x 1000mm W	1800 mm
1200mm D x 800mm W	1800 mm
Minimum clear transfer aisle	2700 mm
Minimum end aisle clearance	750 mm

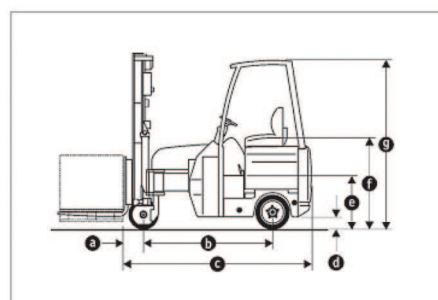
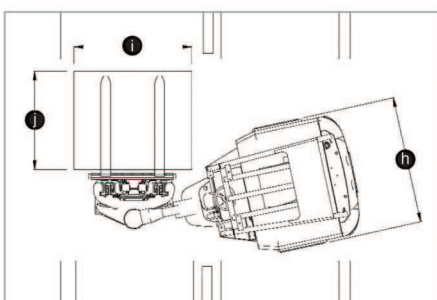

See the Bendi B3 range in Action

download the FREE QR code reader from your app store

Translift Bendi Ltd

Sales/General Enquiries: 01527 527411 Fax: 01527 510177 Email: info@bendi.co.uk

22 Padgets Lane • South Moons Moat Industrial Estate • Redditch • Worcestershire • B98 0RB

www.bendi.co.uk

Bendi