



GREENPOWER
FORKLIFTS

ECO 16-3 / ECO 20-3



The GreenPower Eco 13-3 to 20-3 series is a reliable range of electric counterbalance forklifts designed for efficient handling across multiple industries.

With lifting capacities from 1.3 to 2.0 tonnes, these models offer versatility to meet a wide variety of operational needs.

Each truck is built with a compact design, making them highly maneuverable in tight spaces and narrow aisles.

Energy-efficient electric motors deliver strong performance while reducing operating costs and emissions.

Operators benefit from comfortable cabins, intuitive controls, and excellent visibility for safer working.

Durable, practical, and easy to maintain, the series provides a cost-effective solution for modern material handling.

1.02	Model			CPD135Q	CPD155Q	CPD155Q	CPD165Q	CPD165Q	CPD185Q	CPD185Q	CPD205Q	CPD205Q
1.03	Configuration number			A2LiG3-M	A2Li(P)G3-M	A6LiG3-S	A2Li(P)G3-M	A6LiG3-S	A2Li(P)G3-M	A6LiG3-S	A2Li(P)G3-M	A6LiG3-S
1.04	Rated capacity	Q	kg	1300	1500	1500	1600	1600	1800	1800	2000	2000
1.05	Load center distance	c	mm	500								
1.06	Power mode			Lithium Battery								
1.07	Driving mode			seated								
1.08	Front overhang	x	mm	367	367	367	367	367	367	372	372	372
1.09	Wheelbase	y	mm	1292	1292	1292	1292	1292	1292	1400	1400	1400
Weight												
2.01	Total weight (with/without battery)		kg	2790/2510	2930/2650	2930/2650	3030/2750	3030/2750	3180/2900	3180/2900	3240/2960	3240/2960
2.02	Axle load (laden,front/rear)		kg	3570/520	3870/560	3870/560	4035/595	4035/595	4375/605	4375/605	4600/640	4600/640
2.03	Axle load (unladen,front/rear)		kg	1400/1390	1365/1565	1365/1565	1360/1670	1360/1670	1365/1815	1365/1815	1360/1880	1360/1880
Tyres												
3.01	Tyre type			Solid Tyre	Solid Tyre	Solid Tyre	Solid Tyre	Solid Tyre	Solid Tyre	Solid Tyre	Solid Tyre	Solid Tyre
3.02	Tyre size,front			18×7-8	18×7-8	18×7-8	18×7-8	18×7-8	200/50-10	200/50-10	200/50-10	200/50-10
3.03	Tyre size,rear			140/55-9								
3.04	Number of wheels, front/rear (x= drive wheels)			2×/2								
3.05	Tread, front	b10	mm	920	920	920	920	920	930	930	930	930
3.06	Tread, rear	b11	mm	205								
Dimensions												
4.01	Mast tilt angle (forward/backward)	α/β	°	5/7								
4.02	Height (mast lowered)	h1	mm	2025	2025	2025	2025	2025	2025	2025	2025	2025
4.03	Free lifting height	h2	mm	85	85	85	85	85	85	90	90	90
4.04	Lifting height (standard)	h3	mm	3000								
4.05	Max. height,extended (with backrest)	h4	mm	4038								
4.06	Height of overhead guard	h6	mm	2040								
4.07	Seat height relating to SIP (to ground)	h7	mm	1042								
4.08	Towing coupling height	h10	mm	482								
4.09	Overall length (with fork)	l1	mm	2765	2810	2810	2825	2825	2855	2855	2975	2975
4.10	Overall length (without fork)	l2	mm	1845	1890	1890	1905	1905	1935	1935	2055	2055
4.11	Overall width	b1	mm	1076	1076	1076	1076	1076	1120	1120	1120	1120
4.12	Fork size:thickness x width x length	s/e/l	mm	35×100×920								
4.13	Fork carriage, according to ISO2328			2A								
4.14	Distance across fork-arms, Max./Min.	b5	mm	960/200	960/200	960/200	960/200	960/200	960/200	960/200	1030/200	1030/200
4.15	Ground clearance (at mast)	m1	mm	90								
4.16	Ground clearance (center of wheelbase)	m2	mm	100								
4.17	Right angle stacking aisle width for pallet1000×1200mm crossways	Ast	mm	3155	3200	3200	3220	3220	3250	3250	3370	3370
4.18	Right angle stacking aisle width for pallet800×1200mm lengthways	Ast	mm	3285	3330	3330	3350	3350	3380	3380	3500	3500
4.19	Min. outside turning radius	Wa	mm	1470	1515	1515	1530	1530	1560	1560	1675	1675
Performance Data												
5.01	Travel speed (laden/unladen)		km/h	16/16	16/16	13/14	16/16	13/14	16/16	13/14	16/16	13/14
5.02	Lift speed (laden/unladen)		mm/s	450/600	450/600	350/450	430/600	330/450	430/600	330/450	400/600	300/450
5.03	Lowering speed (laden/unladen)		mm/s	470/500								
5.04	Max.drawbar pull (laden)		N	13500	13500	10200	13500	10200	14000	10200	14000	10200
5.05	Max.gradeability (laden/unladen)		%	20	20	15	20	15	20	15	20	15
5.06	Acceleration time(10m)(laden/unladen)		s	5.4/5	5.4/5	5.4/5	5.4/5	5.4/5	5.4/5	5.4/5	5.4/5	5.4/5
Battery												
6.01	Battery voltage/Capacity		V/Ah	80/150	80/202	80/150	80/202	80/150	80/202	80/150	80/202	80/150
6.02	Battery weight		kg	280	280	280	280	280	280	280	280	280
Motor and controller												
7.01	Driving motor powering (S2-60min)		kW	5.5×2	5.5×2	5.5×2	5.5×2	5.5×2	5.5×2	5.5×2	5.5×2	5.5×2
7.02	Lifting motor powering (S3-15%)		kW	12	16.5	11	16.5	11	16.5	11	16.5	11
7.03	Driving motor controlling mode			MOSFET/AC								
7.04	Lifting motor controlling mode			MOSFET/AC								
Addition data												
8.01	Service brake/Parking brake			Hydraulic/mechanical								
8.02	Relief pressure		Mpa	17.5	17.5	17.5	17.5	17.5	22.5	22.5	22.5	22.5

Note: P refers to the battery side pulling.

Wide View Standard Mast

Mast Model	Max lifting height (mm)	Load capacity (lode center 500mm)(kg)					Height (mast lowered)(mm)	Free lift (with backrest) (mm)		Service weight (kg)					Mast tilting angle (°) α/β
		1.3t	1.5t	1.6t	1.8t	2t		1.3-2t	1.3-1.8t	2t	1.3t	1.5t	1.6t	1.8t	
M200	2000	1300	1500	1600	1800	2000	1525	85	90	2724	2864	2964	3114	3174	5/7
M250	2500	1300	1500	1600	1800	2000	1775	85	90	2757	2897	2997	3147	3207	5/7
M300	3000	1300	1500	1600	1800	2000	2025	85	90	2790	2930	3030	3180	3240	5/7
M330	3300	1300	1500	1600	1800	2000	2175	85	90	2810	2950	3050	3200	3260	5/7
M350	3500	1300	1500	1600	1800	2000	2275	85	90	2823	2963	3063	3213	3273	5/7
M370	3700	1300	1500	1600	1800	2000	2375	85	90	2837	2977	3077	3227	3287	5/7
M400	4000	1300	1500	1600	1800	2000	2575	85	90	2888	3028	3128	3278	3338	3/5
M425	4250	1300	1500	1600	1750	1900	2700	85	90	2905	3045	3145	3295	3355	3/5
M450	4500	1200	1400	1500	1700	1850	2825	85	90	2921	3061	3161	3311	3371	3/5
M500	5000	1100	1300	1400	1600	1700	3075	85	90	2980	3120	3220	3370	3430	3/3

Wide View Full Free 2-Stage Mast

Mast Model	Max lifting height (mm)	Load capacity (lode center 500mm)(kg)					Height (mast lowered)(mm)	Free lift (with backrest) (mm)		Service weight (kg)					Mast tilting angle (°) α/β
		1.3t	1.5t	1.6t	1.8t	2t		1.3-2t	1.3-1.8t	2t	1.3t	1.5t	1.6t	1.8t	
ZM200	2000	1300	1500	1600	1800	2000	1525	510	515	2718	2858	2958	3108	3168	5/7
ZM250	2500	1300	1500	1600	1800	2000	1775	760	765	2749	2889	2989	3139	3199	5/7
ZM300	3000	1300	1500	1600	1800	2000	2025	1010	1015	2780	2920	3020	3170	3230	5/7
ZM330	3300	1300	1500	1600	1800	2000	2175	1160	1165	2798	2938	3038	3188	3248	5/7
ZM350	3500	1300	1500	1600	1800	2000	2275	1260	1265	2810	2950	3050	3200	3260	5/7
ZM370	3700	1300	1500	1600	1800	2000	2375	1360	1365	2822	2962	3062	3212	3272	5/7
ZM400	4000	1300	1500	1600	1800	2000	2575	1560	1565	2872	3012	3112	3262	3322	3/5

Note: the free lifting height increases by 449mm without backrest.

Wide View Full Free 3-Stage Mast

Mast Model	Max lifting height (mm)	Load capacity (lode center 500mm)(kg)					Height (mast lowered)(mm)	Free lift (with backrest) (mm)		Service weight (kg)					Mast tilting angle (°) α/β
		1.3t	1.5t	1.6t	1.8t	2t		1.3-2t	1.3-1.8t	2t	1.3t	1.5t	1.6t	1.8t	
ZSM360	3600	1300	1500	1600	1800	2000	1790	781	786	2899	3039	3139	3289	3349	3/5
ZSM400	4000	1300	1500	1600	1800	2000	1925	916	921	2928	3068	3168	3318	3378	3/5
ZSM435	4350	1200	1400	1500	1700	1900	2040	1031	1036	2948	3088	3188	3338	3398	3/5
ZSM450	4500	1200	1400	1500	1700	1850	2090	1081	1086	2958	3098	3198	3348	3408	3/5
ZSM470	4700	1100	1350	1450	1650	1750	2160	1151	1156	2972	3112	3212	3362	3422	3/5
ZSM480	4800	1100	1350	1450	1650	1750	2190	1181	1186	2978	3118	3218	3368	3428	3/5
ZSM500	5000	1000	1200	1300	1600	1700	2290	1281	1286	2998	3138	3238	3388	3448	3/3
ZSM540	5400	900	1050	1150	1250	1400	2425	1416	1421	3027	3167	3267	3417	3477	3/3
ZSM600	6000	750	800	900	1000	1100	2640	1631	1636	3112	3252	3352	3502	3562	3/3
ZSM650	6500	550	700	800	900	1000	2830	1821	1826	3146	3286	3386	3536	3596	3/3

Note: the free lifting height increases by 449mm without backrest.

Lithium ion battery, Battery charger

Lithium battery brand	HELI				ENEROC			
	80V/150Ah*	80V/202Ah*	80V/280Ah*	80V/404Ah*	80V/150Ah*	80V/228Ah*	80V/302Ah*	80V/346Ah*
Voltage/Capacity								
CPD135Q	●	○	○	○	○	○	○	○
CPD15/16/18SQ S	●	○	○	○	○	○	○	○
CPD15/16/18SQ M	●	○	○	○	○	○	○	○
CPD20SQ S	●	○	○	○	○	○	○	○
CPD20SQ M	●	○	○	○	○	○	○	○
On-board charger	○	○	○	○	○	○	○	○
Low temperature heating of lithium battery	○	○	○	○	○	○	○	○
Charger	D80V100ALI-125 (Recharger) /D80V100ALI-425 (Recharger) /D80V200ALI-123 (Recharger) /D80V200ALI-423 (Recharger)							

Note: ● standard configuration ○ option —not configurable, On-board charger is not available for trucks with side-changing battery.

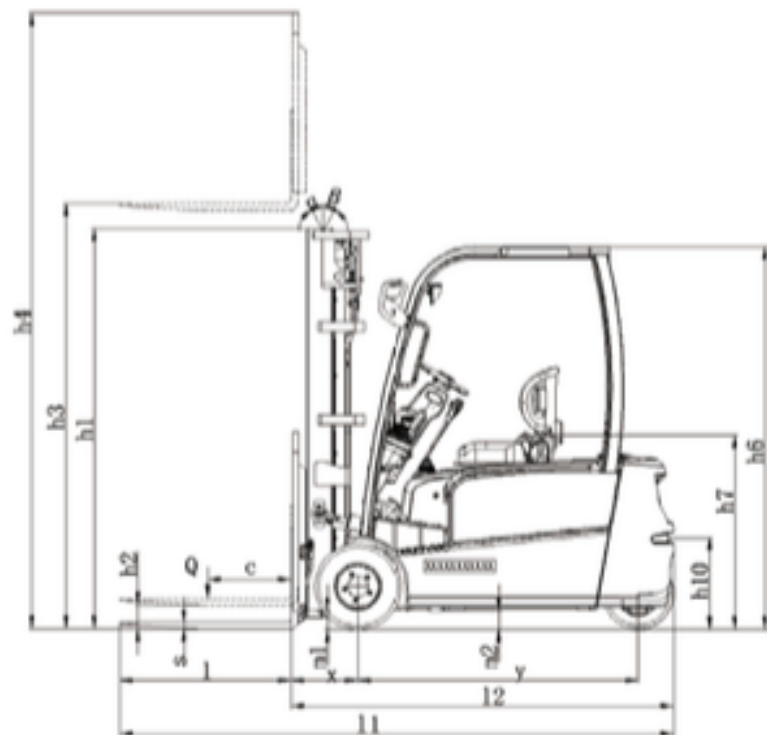

Ast: Right angle stacking aisle width

a: Clearance 200mm

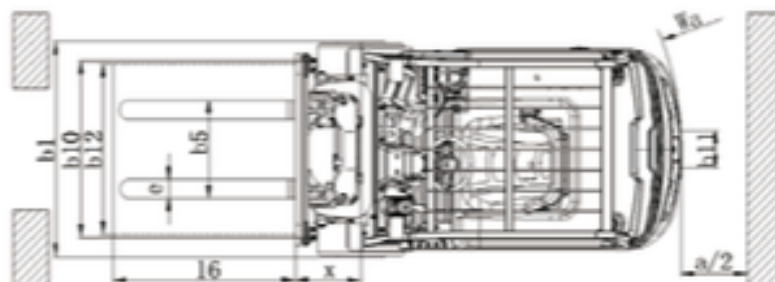

LOAD CURVE

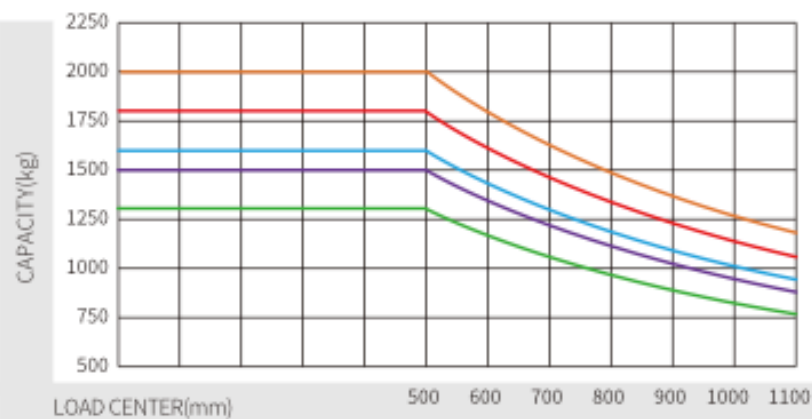

- CPD13SQ
- CPD15SQ
- CPD16SQ
- CPD18SQ
- CPD20SQ

Note: The vertical axis stands for load capacity while the horizontal axis stands for load center which is calculated from the front surface of the forks to the gravity of the standard load. The standard load means a cubic with 1000mm edge length. When the mast is tilted forward, the worker using nonstandard forks for loading large goods, the load capacity will be reduced. The load capacity of standard mast at different load center can be known from this load chart.

Configurations		
For safety	Steering speed limit	●
	Reverse handle with horn	●
	OPS	●
	Safety protecting function of multiway valve overload	●
	Reverse buzzer	●
	Upper buffering	●
	Central wide-angle rearview mirror	●
	Rearview mirrors on two sides	○
	Front protective net	○
	Seat with safety belt	○
	Dry powder fire extinguisher (0.5kg)	○
	Dry powder fire extinguisher (2kg)	○
	Reverse Chinese voice speaker	○
	Reversing parking sensor (4 probes)	○
Reversing image(1 camera+ 4 probes)	○	
For driving comfort	Semi-enclosed seat	●
	USB (5V/1A)	●
	Steering with steering wheel start	●
	Mechanical operation valve	●
	Colorful instrument	●
	Full suspension seat	○
	Electromagnetic operated valve	○
	Fan	○
Heater	○	
For cab/windshield	Panel mounted cab	○
	Front windshield	○
	Rear windshield	○
	Top windshield	○
For lighting	LED lights	●
	LED flickering warning lights	●
	LED rear working light	○
	Front LED red/blue spotlight	○
	Rear LED red/blue spotlight	○
	Red/blue strip lights on rear and bilateral sides	○
	LED rotating warning light	○
LED rotating and beep warning light	○	
Others	Metric thread	●
	Solid tyre	●
	Solid tyre without travelling marking	○
	Sleeve for tilting cylinder	○
	FCIS	●

Note: "●" standard; "○" optional;



ANHUI HELI CO., LTD.

Add / No.668, FangXing Road, Hefei, China

Fax / +86-551-63639966

Tel / +86-551-63639068(America); 63639258(Europe);

63639358(Asia); 63662105(Africa & Middle East)



LinkedIn



YouTube



Facebook

* Our products are subject to improvements and changes without notice.