



USB charging port



Full suspension seat



Ratchet type hand brake

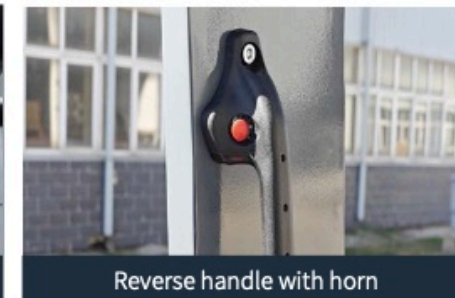

Reverse handle with horn



Electro-hydraulic reversing handle

Various performance tests and rain tests are conducted to ensure that the performance, safety and reliability of the vehicle meets the predetermined standards and requirements.

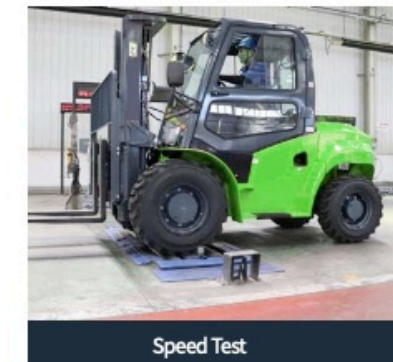

Speed Test

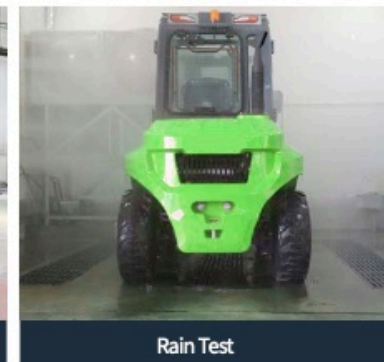

Rain Test

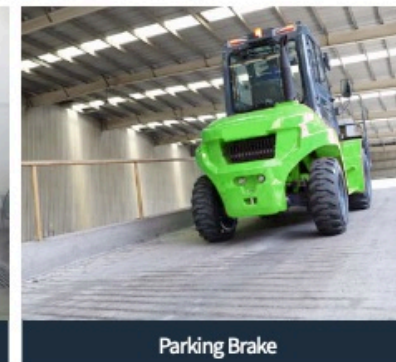

Parking Brake

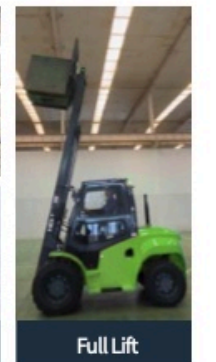

Full Lift

- Smooth appearance, the overall thickening, the use of large pattern special off-road tire, high chassis design, attack a variety of terrain, safe and durable.
- The center of gravity of the vehicle is shifted back, the load distribution of the front and rear Bridges is reasonable, and the carrying capacity is strong.
- The Angle of the frame is 10°/12°, which is convenient for outdoor work.



Special off-road tire with large pattern



Travel speed
2-3.5t:18-19km/h
2-3.5t:23-24km/h
4-5t:28-30km/h



Maximum climbability with full load
2-3.5t:60%
4-5t:40%



Full load lifting speed
2-3.5t:510mm/s
4-5t:500mm/s



No-load lifting speed
2-3.5t:560mm/s
4-5t:550mm/s

Powerful and efficient

- The multi-gear transmission has strong power and superior performance.
- And at the same time takes into account the power and traveling 2-3.5t can be equipped with front 3 rear 3 or front 2 rear 1 gearbox; 4-5t is equipped with front 3 rear 1 gearbox as standard.
- Super large cornering steering axle, time-sharing four-wheel drive function, two-wheel drive and four-wheel drive can be switched at will, energy saving and high efficiency.
- Drive axle + manual differential lock, strong ability to get out of trouble.



Transmission



Differential Lock

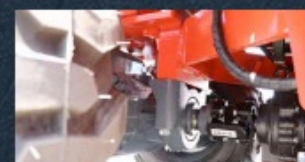

Four-wheel drive

Large hood opening angle

80° hood opening angle, easy for maintenance operation.

Tilting cylinder



Tilting cylinder sinking, lifting the leg space

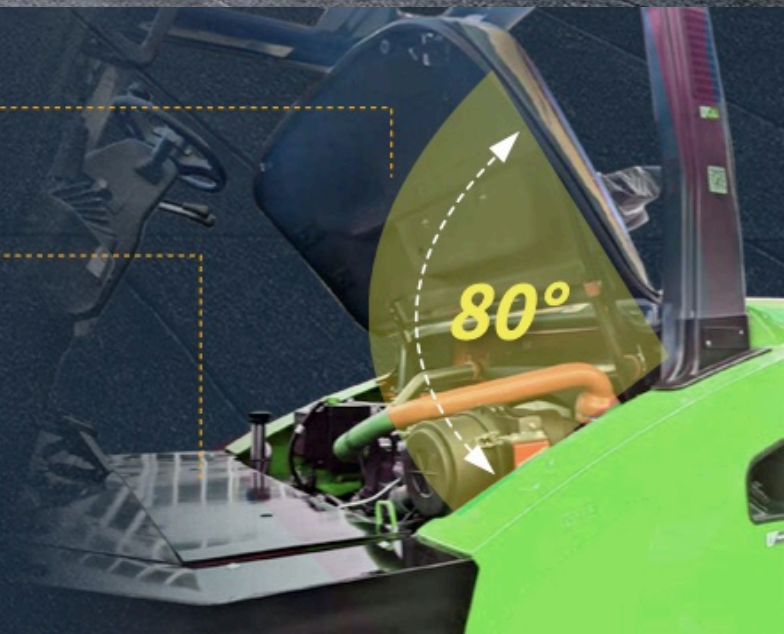



Differential lock is standard on the drive axle:
The differential lock function, activated only when you need it most, gives you the most economical option.



Extra large corner four-wheel drive steering axle, vehicle turning radius is small:
Time-sharing four-wheel drive function, two-wheel drive four-wheel drive switch at will, energy saving and high efficiency.



Engine:
2-3.5t with five power options, 4-5t with four power options, Both domestic and foreign power brands, a wide range of market areas.



The whole vehicle is equipped with LED lamps and lanterns as standard, energy-saving and environmental protection, long-lasting and reliable



Full liquid crystal instrument display



Standard with high temperature protection net, exhaust position high temperature, to protect personnel safety.



Back Up Down OK

1. Colorful LCD display screen with high resolution; adjustable backlight brightness;
2. CAN bus meter to read the fault code directly; (only electronic controlled engine)
3. Front and rear protection degree: IP 66
4. Working temperature: -30°C~+75°C; temperature for storage: -40°C~+85°C;
5. Multi-level programmable menu;
6. More than 20 alarm indicators and 6 simulation indicators can monitor engine and trucks at the same time to protect operator and truck safety;
7. Chinese and English are optional.
8. Point check;
9. Identity recognition(optional); Starting through card or password(optional).

	Engine coolant temperature
	Fuel level
	Oil temperature of drive axle
	LPG pressure
	Low brake pressure
	Engine alarm

	Charging indication
	Block of air cleaner
	Hand brake
	Seat switch
	Neutral indicator
	Safety belt switch

	Left turning
	Right turning
	Alarm of low fuel
	Alarm of engine oil pressure
	Preheating indication
	Hourmeter

	Intelligent shift
	Oil and water separator
	DPF parking regeneration request
	Two-wheel-drive switch
	Forcible no generation of DPF

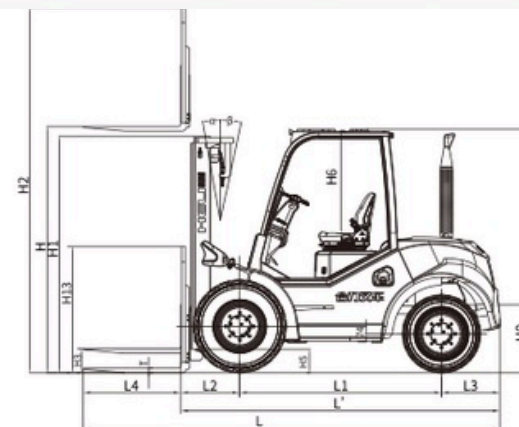

Ast: Right angle stacking aisle width
a: Clearance
L4: Fork Length

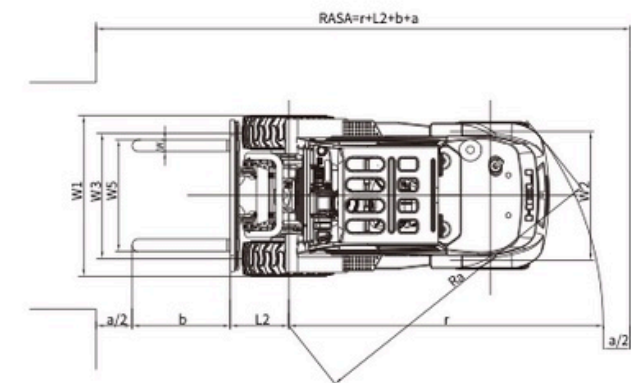

Driving comfort

- Integrated electro-hydraulic reversing handle;
- Full LCD instrumentation;
- Standard electro-hydraulic reversing handle + steering, lamps and lanterns combination handle, to enhance the convenience of operation;
- Reversing handle with horn, reversing more safely;
- Manual differential lock, 2WD and 4WD switching;
- USB charging port; optional air conditioning, heater, to provide a comfortable driving environment; ratchet handbrake, reliable movement, operating force is small; configuration of the full suspension seat, to enhance the comfort of driving.
- The full-suspension seats are equipped to enhance driving comfort.

Equipped with air conditioner
And heater



Manual differential lock



Safe and reliable

- Safe and reliable;
- Lifting system body borrowed from the headquarters of the mature products, wide field of vision, standard with descending buffer;
- Integral stamping roof, high strength, better protection of the driver's safety.

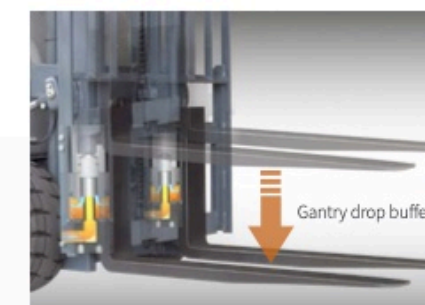

ENGINE MODEL AND MAIN SPECIFICATION FOR OPTION

Configure Models	Engine model	Gearbox instructions	Rate power/Speed (kW/rpm)	Rated torque/speed (Nm/rpm)	Engine displacement (L)	Cylinder number -BorexStroke	Emission	Remarks
CPCD30/35-KU6Y2R-3	KubotaV2607	3-3Power shift	37.4 / 2400	171.5 / 1500	2.615	4-87×110	Euro V/America IV	2WD
CPCD20/25/30/35-KU5Y2R-2	KubotaV2403	2-1Power shift	42.6 / 2400	195.6 / 1500	2.434	4-87×102.4	Euro V/America IV	2WD
CPCD20/25/30/35-W3Y4R-2	ISUZY 4JG2PE-02	2-1Power shift	44.9/2450	184.7/1700	3.059	4-95.4-107	Euro II	4WD
CPCD20/25/30/35-W3Y2R-2	ISUZY 4JG2PE-02	2-1Power shift	44.9/2450	184.7/1700	3.059	4-95.4-107	Euro II	2WD
CPCD30/35-W4Y4R-2	ISUZY GK-4JG2NKFC01	2-1Power shift	35/2450	170/1700	3.059	4-95.4-107	Euro IIIA	4WD
CPCD30/35-W4Y2R-2	ISUZY GK-4JG2NKFC01	2-1Power shift	35/2450	170/1700	3.059	4-95.4-107	Euro IIIA	2WD
CPCD30/35-XC7Y4R-2	XINCHANG3E22	2-1Power shift	44.8/2400	210/1600-1800	2.2	3-94x107	Euro V	4WD
CPCD30/35-XC7Y2R-2	XINCHANG3E22	2-1Power shift	44.8/2400	210/1600-1800	2.2	3-94x107	Euro V	2WD
CPCD20/25/30/35-Q3Y4R-2	QUANCHAIV32-50V42	2-1Power shift	36.8/2500	190/1800	3.17	4-98x105	CHINA IV	4WD
CPCD20/25/30/35-Q3Y2R-2	QUANCHAIV32-50V42	2-1Power shift	36.8/2500	190/1800	3.17	4-98x105	CHINA IV	2WD

Manufacturer and technical parameters									
Character									
1.01	Manufacturer								
1.02	Model		CPCD20-KU5Y4R-2	CPCD25-KU5Y4R-2	CPCD30-KU5Y4R-2	CPCD35-KU5Y4R-2	CPCD30-KU6Y4R-3	CPCD35-KU6Y4R-3	
1.03	Rated Capacity	kg	2000	2500	3000	3500	3000	3500	
1.04	Load Center	mm	500	500	500	500	500	500	
1.05	Power Type		Diesel						
1.06	Operation Mode		Seat-type						
Dimensions									
2.01	Lifting Height(standard)	H	mm	3000	3000	3000	3000	3000	3000
2.02	Mast Overall Height (fork to the ground and mast be vertical)	H1	mm	2225	2225	2225	2275	2225	2275
2.03	Max.Fork Lifting Height(With backrest)	H2	mm	4185	4185	4375	4375	4375	4375
2.04	Free Lift Height	H3	mm	150	150	155	160	155	160
2.05	Overall Height	H4	mm	2420	2420	2420	2420	2420	2420
2.06	Min.Ground Clearance(At the mast)	H5	mm	290	290	290	290	290	290
2.07	Distance From the Surface of the Seat to the Overhead Guard	H6	mm	1263	1263	1263	1263	1263	1263
2.08	Traction Pin Height	H9	mm	450	450	450	450	450	450
2.09	Backrest Height (Calculated from the surface of the fork)	H13	mm	1092	1092	1282	1287	1282	1287
2.10	Overall Length(With fork/Without fork)	(L/L')	mm	4164/3094	4164/3094	4224/3154	4229/3159	4224/3154	4229/3159
2.11	Wheel Base	L1	mm	1940	1940	2000	2000	2000	2000
2.12	Front Overhang	L2	mm	584	584	589	594	589	594
2.13	Rear Overhang	L3	mm	540	540	575	575	575	575
2.14	Overall Width	W1	mm	1600	1600	1600	1600	1600	1600
2.15	Tread (Front tread/Rear tread)	(W3/W2)	mm	1250	1250	1250	1250	1250	1250
2.16	Fork Adjustable Range (the external of the fork)(Max./Min.)	W5	mm	1560/250	1560/250	1560/250	1560/250	1560/250	1560/250
2.17	Min.Turning Radius(Exterior)	r	mm	3513	3513	3585	3585	3585	3585
2.18	Min.Turning Radius(Interior)	r'	mm	1295	1295	1295	1295	1295	1295
2.19	Min.Right Angle Stacking Aisle Width	Ra	mm	5589	5589	5589	5594	5589	5594
2.20	Mast Tilting Angle	α/β	deg.	10/12	10/12	10/12	10/12	10/12	10/12
2.21	Fork Size	(L4xWxT)	mm	1070×122×40	1070×122×40	1070×125×45	1070×125×50	1070×125×45	1070×125×50
Performance									
3.01	Max.Traveling Speed (Loaded/Unloaded)	No differential lock	km/h	19	19	19	19	24	24
		With differential lock	km/h	18	18	18	18	23	23
3.02	Max.Gradeability (Loaded/Unloaded)	No differential lock	%	75	70	65	60	63	57
		With differential lock	%	40	38	38	36	36	32
3.03	Max.Drawbar Pull (Loaded/Unloaded)	No differential lock	kN	32	35	35	38	35	38
		With differential lock	kN	50	50	50	50	50	50
3.04	Lifting Speed (Loaded/Unloaded)	/	mm/s	504/510	504/510	510/560	420/450	510/560	420/450
3.05	Lowing Speed (Loaded/Unloaded)	/	mm/s	470/430	470/430	510/550	455/490	510/550	455/490
Weight									
4.01	Total Weight	kg	4850	5050	5400	5700	5500	5850	
4.02	Weight Distribution Loaded (Front/Rear)	kg	5480/1370	6310/1240	6950/1450	7850/1400	7000/1500	7900/1450	
4.03	Weight Distribution Unloaded (Front/Rear)	kg	1940/2910	2160/2890	2300/3100	2400/3350	2350/3150	2450/3400	
Wheel and Tyre									
5.01	Wheel Number x= Drive Wheel (Front/Rear)			2X/2		2X/2		2X/2	
5.02	Tyre Type(Front/Rear)			Vacuum tyre		Vacuum tyre		Vacuum tyre	
5.03	Tyre Size(Front/Rear)			14-17.5-16PR/10-15.5-10PR		14-17.5-16PR/10-15.5-10PR		14-17.5-16PR/10-15.5-10PR	
5.04	Service Brake			Hydraulic-Foot Pedal		Hydraulic-Foot Pedal		Hydraulic-Foot Pedal	
5.05	Parking Brake			Ratchet parking brake		Ratchet parking brake		Ratchet parking brake	
Drive and Transmission Control Device (Standard configuration without differential lock, optional with differential lock)									
6.01	Battery(Voltage/Capacity)	V/Ah		12/95		12/95		12/95	
6.02	Engine Mode			KubotaV2403		KubotaV2403		KubotaV2607	
6.03	Engine Rated Power	kW/rpm		42.6/2400		42.6/2400		37.4/2400	
6.04	Engine Rated Torque	Nm/rpm		195.6/1500		195.6/1500		171.5/1500	
6.05	Emission			Euro stage V /EPA IV		Euro stage V /EPA IV		Euro stage V /EPA IV	
6.06	Transmission Box Shifting Gears(Front/Rear type)			2-1Power Shift		2-1Power Shift		2-1Power Shift	

WIDE VIEW MAST													
Mast model	Lifting height (mm)	Load capacity (load center 500mm) (kg)				Mast overall height (fork to the ground) (mm)		Service weight (kg)				Mast tilting angle (°) α/β	
		2t	2.5t	3t	3.5t	2-3t	3.5t	2t	2.5t	3t	3.5t		
M300	3000	2000	2500	3000	3500	2230	2280	4720	4920	5500	5850	10/12	
M330	3300	2000	2500	3000	3500	2380	2430	4780	4980	5560	5910	10/12	
M350	3500	2000	2500	3000	3500	2480	2530	4800	5000	5580	5920	10/12	
M370	3700	2000	2500	3000	3500	2580	2630	4820	5020	5600	5940	10/12	
M400	4000	2000	2500	3000	3500	2780	2830	4890	5090	5670	6010	10/12	
M450	4500	2000	2500	3000	3500	3030	3080	4930	5130	5710	6060	10/12	
M500	5000	1650	2100	2600	3300	3280	3330	4980	5180	5760	6100	10/10	
M550	5500	1400	1800	2300	2650	3580	3630	5070	5270	5850	6190	10/10	
M600	6000	1000	1400	1900	2050	3830	3880	5110	5310	5890	6230	10/10	

WIDE VIEW FULL FREE 2-STAGE MAST															
Mast model	Lifting height (mm)	Load capacity (load center 500mm) (kg)				Mast overall height (fork to the ground) (mm)		Free lifting height (with backrest)(mm)			Service weight (kg)				Mast tilting angle (°) α/β
		2t	2.5t	3t	3.5t	2-3t	3.5t	2-2.5t	3t	3.5t	2t	2.5t	3t	3.5t	
ZM300	3000	2000	2500	3000	3500	2230	2280	940	840	943	4770	4970	5550	5820	10/12
ZM330	3300	2000	2500	3000	3500	2380	2430	1090	990	1093	4800	5000	5580	5850	10/12
ZM350	3500	2000	2500	3000	3500	2480	2530	1190	1090	1193	4820	5020	5600	5870	10/12
ZM370	3700	2000	2500	3000	3500	2580	2630	1290	1190	1293	4840	5040	5620	5890	10/12
ZM400	4000	2000	2500	3000	3500	2780	2830	1490	1390	1493	4920	5120	5700	5970	10/12

WIDE VIEW FULL FREE 3-STAGE MAST															
Mast model	Lifting height (mm)	Load capacity (load center 500mm) (kg)				Mast overall height (fork to the ground) (mm)		Free lifting height (with backrest)(mm)			Service weight (kg)				Mast tilting angle (°) α/β
		2t	2.5t	3t	3.5t	2-3t	3.5t	2-2.5t	3t	3.5t	2t	2.5t	3t	3.5t	
ZSM360	3600	2000	2500	3000	3500	2030	2030	740	640	640	5090	5290	5650	5940	10/12
ZSM400	4000	2000	2500	3000	3500	2180	2180	890	790	790	5130	5330	5690	5980	10/12
ZSM435	4350	2000	2500	3000	3500	2280	2280	990	890	890	5160	5360	5720	6010	10/12
ZSM450	4500	2000	2500	3000	3500	2330	2330	1040	940	940	5170	5370	5740	6020	10/12
ZSM470	4700	2000	2500	3000	3400	2390	2390	1100	1000	1000	5190	5390	5760	6040	10/12
ZSM500	5000	1700	2100	2600	3300	2530	2530	1240	1140	1140	5230	5430	5790	6080	10/10
ZSM540	5400	1500	1600	1900	2700	2630	2630	1340	1240	1240	5260	5460	5820	6110	10/10
ZSM600	6000	1000	1100	1500	2000	2830	2830	1540	1440	1440	5360	5560	5930	6210	10/10

Wide view full free 3-stage mast

Mast model	Lifting height (mm)	Load capacity (load center 500mm) (kg)			Mast overall height (fork to the ground) (mm)	Free lifting height (with backrest) (mm)	Service weight (kg)			Mast tilting angle (°) α/β
		4t	4.5t	5t			4-5t	4.5t	5t	
ZSM435	4350	3500	4100	4400	2320	8110	8110	8460	8780	10/12
ZSM450	4500	3350	4000	4200	2370	8130	8130	8480	8800	10/12
ZSM470	4700	3250	3800	4050	2435	8156	8156	8506	8826	10/12
ZSM480	4800	3150	3700	3950	2470	8169	8169	8519	8839	10/12
ZSM500	5000	3050	3400	3800	2570	8209	8209	8559	8879	6/6
ZSM540	5400	2750	3000	3500	2705	8286	8286	8636	8956	6/6
ZSM600	6000	2400	2800	3150	2940	8394	8394	8744	9064	6/6

2-3.5t Standard

Protection for tilting cylinder	Headlights
Warning light	Taillight
Flickering warning light	Two piece multi way valve
OPS controller	Horn
Forks	Reversing buzzer
Traction pin	Large pattern off-road tire
Blocking shelf	Hub bridge (with differential lock)
Overhead guard	Fork width 1600mm
Toolbox	
Turn indicator lamp	
Full suspension seat	

2-3.5t Optional

Cab	Widen fork carrier	Internet of vehicle
Air conditioner	Purification extinguisher	HELI smart fleet management system
Heater	Fire muffler	
Front windshield	Rear working light	
Rear windshield	Optional attachment	
Fire Extinguisher	Lifting slings	
Fan	Protection net of overhead guard	
Dual air cleaner	Reversing voice speaker	
Fork extension	Universal key	
Solid tire	Warning light	
Wet bridge (with differential lock)	Overspeed warning	

4-5t Standard

Protection for tilting cylinder	Headlights
Intermediate exhaust	Taillight
Flickering warning light	Two piece multi way valve
OPS controller	Horn
Forks	Reversing buzzer
Traction pin	Large pattern off-road tire
Blocking shelf	
Overhead guard	
Toolbox	
Turn indicator lamp	
Full suspension seal	

4-5t Optional

Cab	Purification extinguisher	Speed limit function
Air conditioner	Fire muffler	Starting through password or card
Heater	Rear working light	Internet of vehicle
Front windshield	Optional attachment	Smart safety system
Rear windshield	Lifting slings	HELI smart fleet management system
Fire Extinguisher	Protection net of overhead guard	
Fan	Reversing voice speaker	
Dual air cleaner	Universal key	
Fork extension	Rear view camera	
Solid tire	Warning light	
Widen fork carrier	Overspeed warning	

Manufacturer and technical parameters						
Character						
1.01	Manufacturer					
1.02	Model		CPCD40	CPCD45	CPCD50	
1.03	Rated Capacity	kg	4000	4500	5000	
1.04	Load Center	mm		600		
1.05	Power Type			Diesel		
1.06	Operation Mode			Seat-type		
Dimensions						
2.01	Lifting Height(standard)	H	mm	3000	3000	3000
2.02	Mast Overall Height (Fork to the ground and mast be vertical)	H1	mm		2380	
2.03	Max.Fork Lifting Height(With backrest)	H2	mm		4380	
2.04	Free Lift Height	H3	mm		150	
2.05	Overall Height	H4	mm		2580	
2.06	Min.Ground Clearance(At the mast)	H5	mm		320	
2.07	Distance From the Surface of The Seat to the Overhead Guard	H6	mm		1208	
2.08	Traction Pin Height	H9	mm		690	
2.09	Overall Length(With fork/Without fork)	(L/L')	mm		4660/3440	
2.10	Wheel Base	L1	mm		2150	
2.11	Front Overhang	L2	mm		685	
2.12	Rear Overhang	L3	mm		605	
2.13	Overall Width	W1	mm		(2050/1980)	
2.14	Tread (Front tread/Rear tread)	(W3/W2)	mm		1650	
2.15	Fork Adjustable Range (the external of the fork)(Max./Min.)	W5	mm		1340/300	
2.16	Min.Turning Radius(Exterior)	r	mm		4520	
2.17	Min.Right Angle Stacking Aisle Width	Ra	mm		6440	
2.18	Mast Tilting Angle	α/β	deg.		10°/12°	
2.19	Fork Size	(L4xWxT)	mm		1220x155x50	
Performance						
3.01	Max.Traveling Speed (Loaded/Unloaded)	No differential lock	km/h		30	
		With differential lock	km/h		28	
3.02	Max.Gradeability (Loaded/Unloaded)	With differential lock	%		45	
3.03	Max.Drawbar Pull (Loaded/Unloaded)	With differential lock	kN		60	
3.04	Lifting Speed (Loaded/Unloaded)	/	mm/s		500/550	
3.05	Lowing Speed (Loaded/Unloaded)	/	mm/s		450/400	
Weight						
4.01	Self weight (including oil and water)	kg		7450 (7550)	7800 (7900)	8100 (8200)
Wheel and Tyre						
5.01	Wheel Number x = Drive Wheel (Front/Rear)				2X/2	
5.02	Tyre Type(Front/Rear)				Vacuum tyre	
5.03	Tyre Size(Front/Rear)				385/65-22.5-16TL/12-16.5-10-TL	
5.04	Service Brake				Hydraulic-Foot Pedal	
5.05	Parking Brake				Ratchet parking brake	

Wide view mast										
Mast model	Lifting height (mm)	Load capacity (load center 500mm) (kg)			Mast overall height (fork to the ground) (mm)	Free lifting height (with backrest) (mm)	Service weight (kg)			Mast tilting angle (°) α/β
		4t	4.5t	5t			4t	4.5t	5t	
M260	2600	4000	4500	5000	2200	150	7716	8066	8386	10/12
M270	2700	4000	4500	5000	2250	150	7728	8078	8398	10/12
M300	3000	4000	4500	5000	2400	150	7762	8112	8432	10/12
M330	3300	4000	4500	5000	2550	150	7796	8146	8466	10/12
M350	3500	4000	4500	5000	2650	150	7819	8169	8489	10/12
M370	3700	4000	4500	5000	2750	150	7842	8192	8512	10/12
M400	4000	4000	4500	5000	2950	150	7931	8281	8601	10/12
M425	4250	4000	4500	5000	3075	150	7951	8301	8621	10/12
M450	4500	4000	4500	5000	3200	150	7980	8330	8650	10/12
M475	4750	3500	4000	4250	3325	150	8009	8359	8679	10/12
M500	5000	3200	3600	4000	3450	150	8036	8386	8706	10/6
M550	5500	2900	3200	3600	3700	150	8142	8492	8812	10/6
M600	6000	2600	3000	3300	3950	150	8198	8548	8868	10/6

Wide view full free 2-stage mast										
Mast model	Lifting height (mm)	Load capacity (load center 500mm) (kg)			Mast overall height (fork to the ground) (mm)	Free lifting height (with backrest) (mm)	Service weight (kg)			Mast tilting angle (°) α/β
		4t	4.5t	5t			4t	4.5t	5t	
ZM261	2610	4000	4500	5000	2240	900	7812	8162	8482	10/12
ZM271	2710	4000	4500	5000	2290	950	7827	8177	8497	10/12
ZM300	3000	4000	4500	5000	2435	1095	7762	8112	8432	10/12
ZM330	3300	4000	4500	5000	2585	1245	7913	8263	8583	10/12
ZM350	3500	4000	4500	5000	2685	1345	7942	8292	8612	10/12
ZM375	3750	4000	4500	5000	2810	1470	7978	8328	8648	10/12
ZM400	4000	4000	4500	5000	2935	1595	8035	8385	8705	10/12
ZM450	4500	3700	4200	4500	3185	1845	8107	8457	8777	10/12
ZM500	5000	3200	3600	4000	3435	2095	8177	8527	8847	6/6
ZM550	5500	2900	3200	3600	3685	2345	8296	8646	8966	6/6
ZM600	6000	2600	3000	3300	3935	2595	8345	8695	9015	6/6

Drive, transmission control device (standard without differential lock, optional with differential lock), Optional forklift engine models and their main technical parameters									
Engine model	Engine description	Configure the vehicle model	Configure the vehicle model	Rated power /speed	Rated torque /speed	Engine displacement	Number of engine cylinders-cylinder diameter X stroke-94 X 120	Emission standard	
Kubota V3307	Electronically controlled high pressure common rail + supercharged intercooling + DOC+DPF+EGR	CPCD40-50-KU4Y4(2)R-3-06	12/95	55.4/2200	335/1400	3.33	4-94 X 120	Euro V/US IV/CHINA V	
QUANCHAI V35-88C41	498 electronically controlled high pressure common rail + supercharged intercooling + DOC+DPF+EGR	CPCD40-50-QC13Y4(2)R-3-6	12/95	65/2200	350/1800	3.47	4-98 X 115	CHINA IV	
QUANCHAI4C6-88C31	498 electronically controlled high pressure common rail + pressurized intercooling	CPCD40-50-QC7Y4(2)R-3-06	12/95	65/2200	350/1800	3.47	4-98 X 115	CHINA III	
MitsubishiS6S-T	VE pump + turbocharging	CPCD40-50-M1Y2R-3-06	2 X 12/80	63.9/2300	285/1700	4.996	6-94 X 120	Euro IIIA	

Wide view full free 3-stage mast										
Mast model	Lifting height (mm)	Load capacity (load center 500mm) (kg)			Mast overall height (fork to the ground) (mm)	Free lifting height (with backrest) (mm)	Service weight (kg)			Mast tilting angle (°) α/β
		4t	4.5t	5t			4-5t	4-5t	4t	
ZSM435	4350	3500	4100	4400	2320	8110	8110	8460	8780	10/12
ZSM450	4500	3350	4000	4200	2370	8130	8130	8480	8800	10/12
ZSM470	4700	3250	3800	4050	2435	8156	8156	8506	8826	10/12
ZSM480	4800	3150	3700	3950	2470	8169	8169	8519	8839	10/12
ZSM500	5000	3050	3400	3800	2570	8209	8209	8559	8879	6/6
ZSM540	5400	2750	3000	3500	2705	8286	8286	8636	8956	6/6
ZSM600	6000	2400	2800	3150	2940	8394	8394	8744	9064	6/6



ANHUI HELI CO., LTD.

Add / No.668, FangXing Road, Hefei, China

Fax / +86-551-63639966

Tel / +86-551-63639068(America); 63639258(Europe);
63639358(Asia); 63662105(Africa & Middle East)



LinkedIn



YouTube



Facebook

* Our products are subject to improvements and changes without notice.